

Model #44060 HAND PUNCH



3491 Mission Oaks Blvd., Camarillo, CA 93011
Visit our Web site at <http://www.harborfreight.com>

Copyright © 2000 by Harbor Freight Tools. All rights reserved. No portion of this manual or any artwork contained herein may be reproduced in any shape or form without the express written consent of Harbor Freight Tools.

For technical questions please call 1-800-444-3353

UNPACKING

When unpacking, check to make sure all parts shown on the back of this instruction sheet are included. If any parts are missing or broken, please call Harbor Freight Tools at the number shown on the front of this instruction sheet as soon as possible.

OPERATING INSTRUCTIONS

All parts mentioned below refer to parts shown on the reverse side of this instruction sheet.

1. **NOTE:** The maximum material (aluminum, copper, soft metal, etc.) thickness capacity for this Hand Punch is 18 gauge.
2. To change the Punches (part #14), remove the Lower Handle Screw (part #3) and pull the Upper Handle (part #1) back to release the Punch from the Eccentric Arm Slot (part #10) (**Figure A**). Lift the Punch from the guide hole (**Figure B**). Install a new Punch in the guide hole and move the Eccentric Arm (part #10) forward until the slot in the Punch is engaged in the Eccentric Arm. Replace the Lower Handle Screw.
3. To attach Dies (part #15) onto the Lower Handle (part #2), use the Die Adjusting Key (part #12) or a screwdriver to install and adjust the depth of the Die. **NOTE:** The depth of the Die should be adjusted high enough to allow the Punch to remove the slug of the workpiece material.

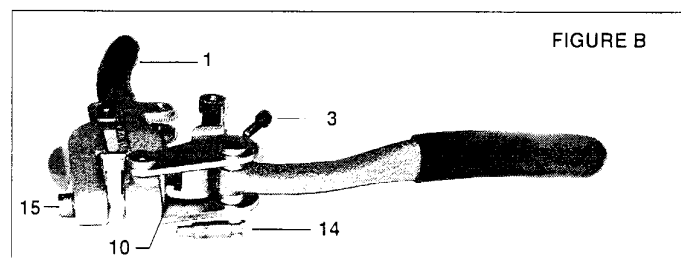
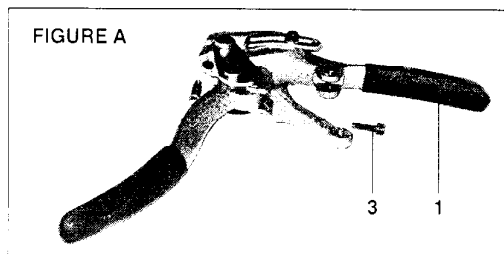

CLEANING AND MAINTENANCE

1. To clean, wipe with a clean, damp cloth. Using a mild soap with water if necessary. Then, dry.
2. For better product performance, apply a light lubricant to all moving parts, the punch guide hole in the Lower Handle (part #2), and the punch points (part #14).

**SEE REVERSE SIDE OF THIS INSTRUCTION FLYER FOR PRODUCT WARNINGS,
PRECAUTIONS, PARTS LIST, AND ASSEMBLY DIAGRAM.**

SAFETY WARNINGS AND PRECAUTIONS

1. **KEEP PRODUCT USAGE AREA CLEAN.**
Cluttered areas invite injuries.
2. **KEEP CHILDREN AWAY FROM PRODUCT USAGE AREA.** Do not allow children to handle this product.
3. **DO NOT USE THIS PRODUCT IF UNDER THE INFLUENCE OF ALCOHOL OR DRUGS.** Read warning labels on prescriptions to determine if your judgement or reflexes are impaired while taking drugs. If there is any doubt, do not attempt to use this product.
4. **USE EYE PROTECTION.** Wear ANSI approved safety impact eye goggles. The ANSI approved safety impact goggles are available from Harbor Freight Tools.
5. **CHECK FOR DAMAGED PARTS.** Before using this product, carefully check that it will operate properly and perform its intended function. Check for damaged parts and any other conditions that may affect its operation. Replace or repair damaged or worn parts immediately.
6. **REPLACEMENT PARTS AND ACCESSORIES.**
When servicing, use only identical replacement parts. Only use accessories intended for use with this product. Approved accessories are available from Harbor Freight Tools.
7. **MAINTENANCE:** Service and maintenance should be performed regularly by a qualified technician.

8. **USE THE RIGHT PRODUCT FOR THE RIGHT JOB.**
There are certain applications for which this product was designed. Do not use a smaller tool to do the work required by a larger industrial size tool. Do not use this product for a purpose for which it was not intended.

SAVE THIS INSTRUCTION SHEET

You will need this instruction sheet for the Operating and Maintenance Procedures, and Safety Warnings and Precautions. Keep your invoice with this instruction sheet. Write the invoice number on the the front of this instruction sheet. Keep this instruction sheet and invoice in a safe and dry place for future reference.

PLEASE READ THE FOLLOWING CAREFULLY

THE MANUFACTURER AND/OR DISTRIBUTOR HAS PROVIDED THE PARTS DIAGRAM IN THIS MANUAL AS A REFERENCE TOOL ONLY. NEITHER THE MANUFACTURER NOR DISTRIBUTOR MAKES ANY REPRESENTATION OR WARRANTY OF ANY KIND TO THE BUYER THAT HE OR SHE IS QUALIFIED TO MAKE ANY REPAIRS TO THE PRODUCT OR THAT HE OR SHE IS QUALIFIED TO REPLACE ANY PARTS OF THE PRODUCT. IN FACT, THE MANUFACTURER AND/OR DISTRIBUTOR EXPRESSLY STATES THAT ALL REPAIRS AND PARTS REPLACEMENTS SHOULD BE UNDERTAKEN BY CERTIFIED AND LICENSED TECHNICIANS AND NOT BY THE BUYER. THE BUYER ASSUMES ALL RISK AND LIABILITY ARISING OUT OF HIS OR HER REPAIRS TO THE ORIGINAL PRODUCT OR REPLACEMENT PARTS THERETO, OR ARISING OUT OF HIS OR HER INSTALLATION OF RE-

PARTS LIST / ASSEMBLY DIAGRAM

PART #	DESCRIPTION	QTY
1	Upper Handle	1
2	Lower Handle	1
3	Lower Handle Screw	1
4	Cam Pin	1
5	Gauge	1
6	Gauge Screw	1
7	Eccentric Pin	2
8	Eccentric Side Link	2
9	Washer	4
10	Eccentric Arm	1
11	Washer	2
12	Die Adjusting Key	1
13	Hex Wrench	1
14	Punch Set: 7mm-9/32", 6mm-1/4", 5.5mm-7/32", 4.5mm-3/16", 4mm-5/32", 3mm-1/16", 2mm-3/32"	1 ea.
15	Die Set: 7mm-9/32", 6mm-1/4", 5.5mm-7/32", 4.5mm-3/16", 4mm-5/32", 3mm-1/8", 2mm-3/32"	1 ea.
16	Plastic Carrying Case (Not Shown)	1

ASSEMBLY DIAGRAM

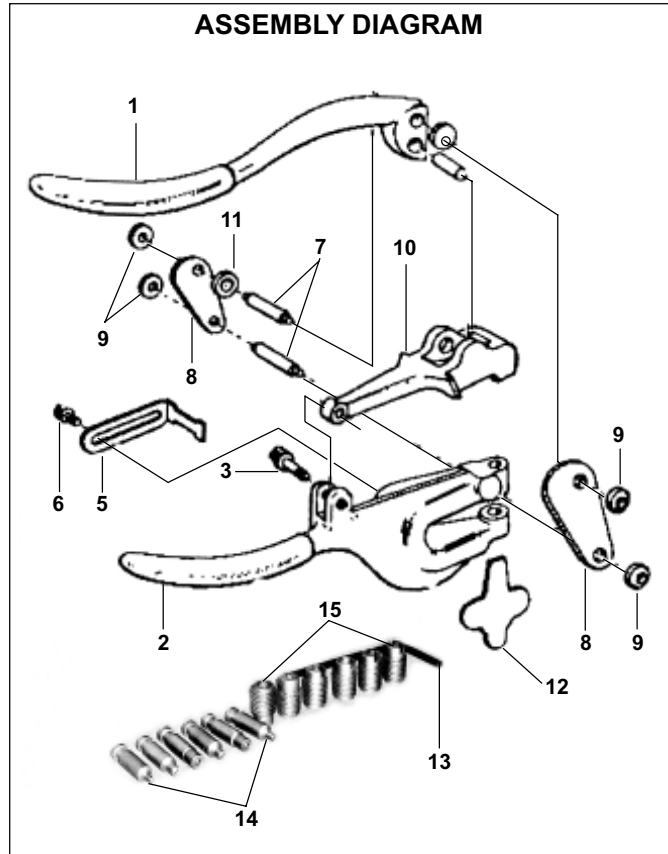

NOTE: Some parts are listed and shown for illustration purposes only, and are not available individually as replacement parts.